

# TECH<sup>4</sup>O<sup>®</sup>

*NOTHING'S BEYOND YOU.*



**ACCELERATOR OWNER'S MANUAL**

# ACCELERATOR SERIES INSTRUCTION MANUAL

## TABLE OF CONTENT

|              |       |
|--------------|-------|
| Introduction | pg. 3 |
| Buttons      | pg. 3 |

### Major Functions Modes: pg. 4

|                      |       |
|----------------------|-------|
| Menu System          | pg. 4 |
| Home Time Display    | pg. 4 |
| Dual Time View       | pg. 5 |
| Chronograph Mode     | pg. 5 |
| Countdown Timer Mode | pg. 6 |
| Exercise Mode        | pg. 8 |

### Exercise Settings Menu pg. 9

|                          |        |
|--------------------------|--------|
| 1 of 4 Memory Save/Clear | pg. 9  |
| 2 of 4 Exercise History  | pg. 10 |
| 3 of 4 Exercise Schedule | pg. 11 |
| 4 of 4 Pedometer Setting | pg. 12 |

### Main Settings Menu pg. 13

|                            |        |
|----------------------------|--------|
| 1 of 10 Home Time Setting  | pg. 13 |
| 2 of 10 Alarm Setting      | pg. 14 |
| 3 of 10 Exercise Schedule  | pg. 15 |
| 4 of 10 Pedometer Setting  | pg. 16 |
| 5 of 10 Memory Save/Clear  | pg. 17 |
| 6 of 10 Exercise History   | pg. 18 |
| 7 of 10 Timer Setting      | pg. 19 |
| 8 of 10 Personal Profile   | pg. 20 |
| 9 of 10 System Setting     | pg. 21 |
| 10 of 10 Dual Time Setting | pg. 21 |

### Power Saving Mode pg. 22

### Battery pg. 22

### Trouble Shooting pg. 23

### Warranty pg. 23

## INTRODUCTION

Thank you for purchasing a Tech4O Accelerator Series Watch. Your watch uses advanced accelerometer sensor technology to accurately measure speed, distance, and calories,

Although your Accelerator watch has a pre-programmed profile, it is extremely important to enter your own profile in the MAIN SETTINGS MENU – **8 of 10** Personal Profile.

Accurate measurement and input of your weight and walking/running stride lengths is crucial to achieving accurate results. For help with measuring your average strides, visit [www.tech4o.com](http://www.tech4o.com) and use the stride length calculator on the Accelerator product pages.

Your new Tech4O Accelerator watch uses an easy to navigate menu system to access and adjust its various modes. Understanding how to access, navigate, and exit the two menus is important to enjoying your new watch.



fig. 1

## BUTTONS see fig.1

- LIGHT** • Turns on electro-luminescent backlight
- MODE** • Enters/exits setting modes
  - Selects among major functions
  - Moves among different items in setting modes
- ST/STP** • Activates start and stop features in several modes
  - Scrolls to previous menu items
  - Increases values in setting modes
- LAP/RESET** • Enters/exits Exercise Mode
  - Resets/reloads values in several modes
  - Scrolls to next menu item
  - Decreases values in setting modes

## MAJOR FUNCTION MODES see fig.2

Your Accelerator Watch has four major functions and two primary menus:

- **Home Time/Dual Time**
- **Chronograph**
- **Countdown Timer**
- **Exercise Mode**

Exercise Mode and Home Time Mode each have their own menu system. See below

### EXERCISE MENU

- 1 of 4 Memory Save/Clear
- 2 of 4 Exercise History
- 3 of 4 Exercise Schedule
- 4 of 4 Pedometer Setting

### MAIN SETTING MENU

- 1 of 10 Home Time Setting
- 2 of 10 Alarm Setting
- 3 of 10 Exercise Schedule
- 4 of 10 Pedometer Setting
- 5 of 10 Memory Save/Clear
- 6 of 10 Exercise History
- 7 of 10 Timer Setting
- 8 of 10 Personal Profile
- 9 of 10 System Editing
- 10 of 10 Dual Time Setting

Note: For your convenience, these two menus share four features. They can be accessed through either of the two menus

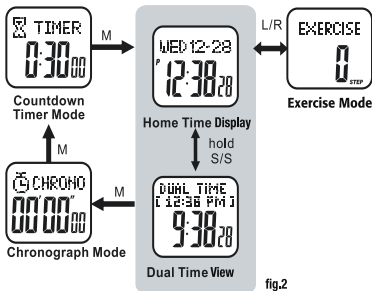

fig.2

### Home Time Display see fig. 2

The home time display is the default display.

In any settings mode, if no button is pressed for one minute, the watch will automatically and continually revert to each previous display, until it reaches the home time display.

### Home Time Mode Display

Top line: day of week, month, and date

or Home Time if in the Dual Time View

Bottom line: current Home Time or Dual

Time if in Dual Time View

**To set home time**, see MAIN SETTINGS MENU– Home Time Setting: **1 of 10**

### Dual Time View:

Your accelerator watch is capable of storing an alternate time zone. There are 2 ways to view dual time zones:

- **QUICK VIEW-** PRESS **ST/STP** in the home time display. The dual time zone will appear for 3 seconds. After 3 seconds the home time display will return
  - **DUAL VIEW-** HOLD **ST/STP** FOR 3 SECONDS in the home time display. Home time will appear in the top line. The dual time zone time will show in the bottom line
- HOLD **ST/STP** FOR 3 SECONDS to return the view to home time display

**To set dual time**, see MAIN SETTINGS MENU - Dual Time Setting: **10 of 10**

**Chronograph Mode:** see fig. 3

- PRESS **MODE** ONCE from the home time display to access the chronograph

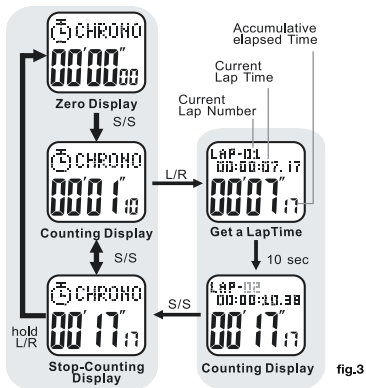

fig.3

### Chronograph Mode displays:

Top line: CHRONO

Bottom line: running time- minutes, seconds, and hundredth seconds for the first hour OR hours, minutes and seconds thereafter

**To Use the Chronograph Mode:** see fig.3.

- PRESS **ST/STP** to start the chronograph
- PRESS **ST/STP** again to stop the chronograph

### To Record Lap Times:

- PRESS **ST/STP** or start the chronograph
- PRESS **LAP/RESET** to record a lap time

The recorded lap time will display in the top line for 10 seconds. After 10 seconds the current lap time will display in the top line and the current total elapsed time will display in the bottom line. Repeat the above steps to record additional lap times. A total of 50 lap times can be recorded

- PRESS **ST/STP** to stop the chronograph

### To View the Recorded Lap Times:

see fig.4  
HOLD MODE FOR 3 SECONDS

- PRESS **ST/STP** to view first lap time (REC-01)

Recorded lap time will display in top line  
Total elapsed time will display in the bottom line

- PRESS **ST/STP** again to view additional recorded lap times

HOLD MODE FOR 3 SECONDS to exit the chronograph memory

- PRESS **MODE** to exit chronograph mode

### To Clear the Chronograph:

HOLD LAP/RESET FOR 3 SECONDS to clear the chronograph memory

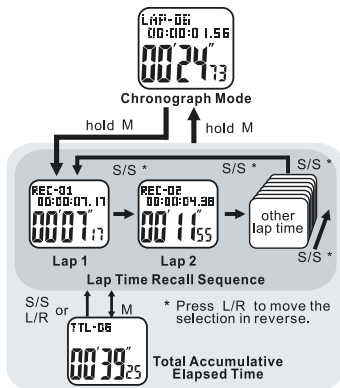

### Countdown Timer Mode:

see fig.5  
Your Accelerator watch has a convenient countdown timer. The timer can be used for advanced training or as a quick reminder. The timer counts backwards from your programed time and beeps at critical intervals. See the following steps to set the countdown timer.

**Countdown Timer Mode Displays:** see fig.5

Top line: TIMER → RUN → PAUSE → FINISH

Bottom line: hours, minutes, seconds

- PRESS **MODE** TWICE from the home time display to access countdown timer

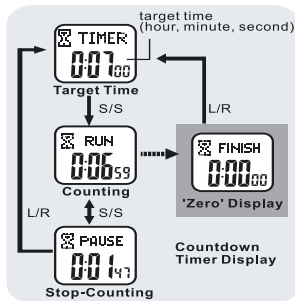

fig.5

**To Use the Countdown Timer:** see fig.5

- PRESS **ST/STP** to start countdown timer
- PRESS **ST/STP** to stop countdown timer

The countdown timer will beep:

On the minute for the last 10 minutes.

Every 10 seconds during the last minute.

Every second for the last 5 seconds.

For 10 seconds at expiration

**To Set the Countdown Timer:** see fig.6

HOLD **MODE** FOR 3 SECONDS in the countdown timer display to access the settings menu

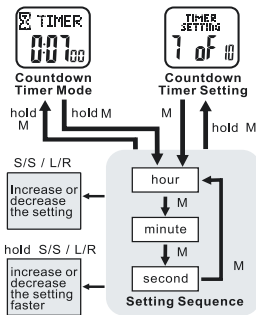

fig.6

- PRESS **ST/STP** or **LAP/RESET** to adjust the hours
- PRESS **MODE** to confirm
- PRESS **ST/STP** or **LAP/RESET** to adjust the minutes
- PRESS **MODE** to confirm
- PRESS **ST/STP** or **LAP/RESET** to adjust the seconds
- PRESS **MODE** to confirm

HOLD **MODE** FOR 3 SECONDS to return to the Countdown Timer display

### To Re-Set the Countdown Timer:

- PRESS **LAP/RESET** when the countdown timer is stopped or at expiration to reset
- PRESS **MODE** to exit Countdown Timer Mode

### Exercise Menu:

Your Accelerator's exercise mode accurately measures your speed, distance, calories, and steps.

Although your Accelerator watch has a pre-programmed profile, it is extremely important to enter your personal profile. Enter your personal profile in the MAIN SETTINGS MENU – Personal Profile: **8 of 10**.

Accurate measurement of your weight and walking/running stride lengths is crucial to achieving accurate results. For help with measuring your average stride lengths, visit [www.tech4o.com](http://www.tech4o.com) and use the stride length calculator on the Accelerator product page. See the following steps on how to access and navigate Exercise Mode.

### Exercise Mode Displays:

- PRESS **LAP/RESET** from the Home Time display to access Exercise Mode

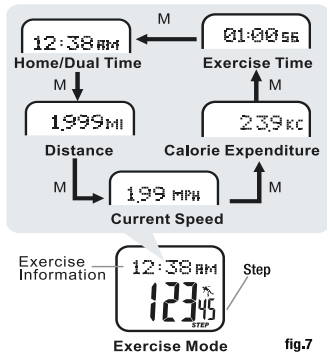

fig.7

### To Use the Exercise Mode: see fig.7

After an 8 second initiation, Exercise Mode will automatically begin recording exercise data when you start walking or running. The Accelerator will also automatically adjust between your walking and running stride.

- PRESS **MODE** to scroll through the various exercise data on the top of the display (time of day, distance, speed, calories, exercise time)
- PRESS **ST/STP** to manually start or stop recording
- PRESS **LAP/RESET** to exit Exercise Mode

### EXERCISE MODE SETTINGS MENU:

HOLD **MODE** FOR 3 SECONDS in Exercise Mode to access the Exercise Settings Menu

Note: the four menu selections:

Memory Save/Clear: **1 of 4**

Exercise History: **2 of 4**

Exercise Schedule: **3 of 4**

Pedometer Setting : **4 of 4**

are also accessible through the MAIN SETTINGS MENU- **3-6 of 10**

**Memory Save/Clear: 1 of 4** see fig.8  
Your Accelerator watch makes it easy to save or delete any current exercise data that has been recorded in exercise mode. See the following steps to save or clear current exercise data.

HOLD **MODE** FOR 3 SECONDS in Exercise Mode to access the Exercise Settings Menu

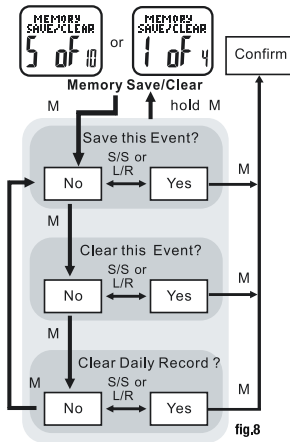

- PRESS **ST/STP** or **LAP/RESET** to scroll to Memory Save/Clear: **1 of 4**
- PRESS **MODE** to enter Memory Save/Clear: **1 of 4**
- Press **MODE** to scroll through the various saving/clearing options:

SAVE THIS EVENT = saves data currently being recorded in exercise mode

Clear this event = deletes data currently being recorded in exercise mode

Clear daily record = deletes previously saved data for the current day, but maintains data currently being recorded in exercise mode

- Press **ST/STP** to select between yes/no
- Press **MODE** to confirm selection

Hold **MODE** for 3 seconds to return to the Exercise Settings Mode

Hold **MODE** for 3 seconds to return to Exercise Mode

### Exercise History: 2 of 4 see fig.9

Your Accelerator watch contains a vast amount of internal memory. Daily exercise data is automatically stored every night at midnight. The watch's memory will store up to 7 days of individual daily exercise data and log the current day. After 7 days, the daily data is automatically cataloged into a weekly exercise record. The Accelerator's memory stores 10 weeks of records plus the last 7 days as daily exercise data. All data is stored on a rolling counter i.e.: after 10 weeks, the oldest record is replaced by the most recent

weekly data. See the following steps to access the Accelerator's internal memory.  
HOLD MODE FOR 3 SECONDS in Exercise Mode to access the Exercise Settings Menu

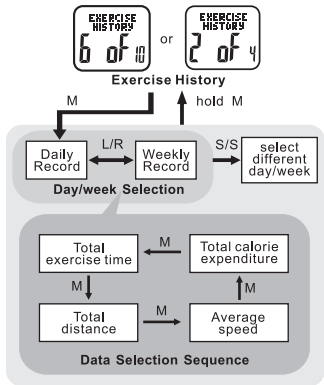

fig.9

- PRESS **ST/STP** or **LAP/RESET** to scroll to Exercise History: **2 of 4**
- PRESS **MODE** to enter Exercise History: **2 of 4**
- PRESS **LAP/RESET** to select →

between daily (previous seven days) or weekly (previous ten weeks records)

Example: **12-20D** = daily exercise record for December 20th

Example: **51W** = weekly exercise record for the 51st week of the year

• PRESS **ST/STP** to select the proper day or week

HOLD **MODE** FOR 3 SECONDS to return to the Exercise Mode Settings Menu

HOLD **MODE** FOR 3 SECONDS to return to the Exercise Mode

### Exercise Schedule: 3 of 4

see fig.10  
Your Accelerator watch has a useful scheduling feature for exercise mode. This feature allows you to determine specific times of the day when exercise mode will automatically turn on and off so that you don't accidentally forget to record important data.

Six start and/or stop times can be set in the exercise schedule. See the following steps to set your own exercise schedule.

HOLD **MODE** FOR 3 SECONDS in Exercise Mode to access the Exercise Settings Menu

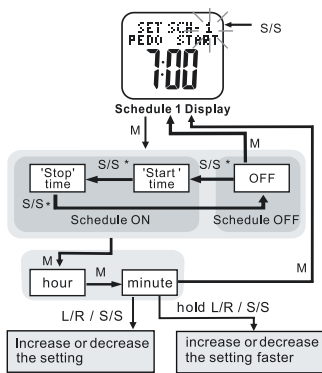

\* Press L/R to move the selection by a reverse direction.

\*\*Either a 'start' or 'stop' time can be set for a schedule  
fig.10

- PRESS **ST/STP** or **LAP/RESET** to scroll to Exercise Schedule: **3 of 4**
- PRESS **MODE** to enter Exercise Schedule: **3 of 4**
- PRESS **ST/STP** to select from one of the six exercise schedule start/stop times
- PRESS **MODE** to confirm

- PRESS **ST/STP** to select between off / start / stop
- PRESS **MODE** to confirm
- PRESS **ST/STP** or **LAP/RESET** to adjust the hour. Check whether the hour is for AM or PM
- PRESS **MODE** to confirm
- PRESS **ST/STP** or **LAP/RESET** to adjust the minutes
- PRESS **MODE** to confirm

Repeat above steps to set the remaining exercise schedule start/stop times

HOLD **MODE** FOR 3 SECONDS to return to

Exercise Mode Settings Menu

HOLD **MODE** FOR 3 SECONDS to return to

Exercise Mode

### **Pedometer Setting: 4 of 4** see fig.11

Your accelerator watch is highly customizable; just tailor the accelerometer sensor to match your workout. See the following steps to adjust the sensitivity and sleep timer of exercise mode.

HOLD **MODE** FOR 3 SECONDS in Exercise Mode to access Exercise Settings Menu

- PRESS **ST/STP** or **LAP/RESET** to scroll to Pedometer Setting: **4 of 4**

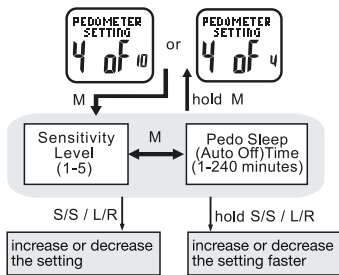

**Pedometer Setting** fig.11

- PRESS **MODE** to enter Pedometer Setting: **4 of 4**
- PRESS **ST/STP** to adjust the pedometer's sensitivity level from 1-5

Note: Sensitivity range is from 1=least sensitive to 5=most sensitive. In most cases, level 1 is recommended for accurate results

- PRESS **MODE** to confirm
- PRESS **ST/STP** or **LAP/RESET** to ↩

adjust pedometer's sleep timer from 1 to 240 minutes

- PRESS **MODE** to confirm

HOLD **MODE** FOR 3 SECONDS to return to Exercise Mode Settings Menu

HOLD **MODE** FOR 3 SECONDS to return to Exercise Mode

### MAIN SETTINGS MENU:

The main settings menu is used to calibrate the various settings of your accelerator watch.

Note: The main settings menu can only be accessed via the home time display. If no button is pressed for 1 minute, the watch will continually scroll through the previous screens until it returns to the home time display

**Home Time Setting: 1 of 10** see fig.12  
HOLD **MODE** FOR 3 SECONDS in the home time display to access the Main Settings Menu

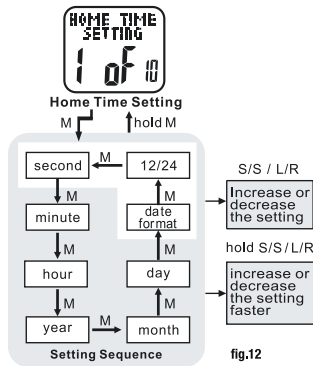

- PRESS **MODE** to enter Home Time Setting: **1 of 10**
- PRESS **ST/STP** or **LAP/RESET** to zero the seconds
- PRESS **MODE** to confirm
- PRESS **ST/STP** or **LAP/RESET** to adjust the minutes
- PRESS **MODE** to confirm
- PRESS **ST/STP** or **LAP/RESET** to adjust the hour. Check whether the →

hour is for AM or PM

- PRESS **MODE** to confirm
- PRESS **ST/STP** or **LAP/RESET** to adjust the year
- PRESS **MODE** to confirm
- PRESS **ST/STP** or **LAP/RESET** to adjust the month
- PRESS **MODE** to confirm
- PRESS **ST/STP** or **LAP/RESET** to adjust the day
- PRESS **MODE** to confirm
- PRESS **ST/STP** or **LAP/RESET** to adjust the day/month or month/day format
- PRESS **MODE** to confirm
- PRESS **ST/STP** or **LAP/RESET** to adjust the time format
- PRESS **MODE** to confirm

HOLD **MODE** FOR 3 SECONDS to return to the Main Settings Menu

HOLD **MODE** FOR 3 SECONDS to return to the Home Time display

**Alarm Setting: 2 of 10** see fig.13

Your Accelerator watch has 5 Daily Alarm Settings. See the following steps to set the daily alarms.

HOLD **MODE** FOR 3 SECONDS in the home time display to access the Main Settings Menu

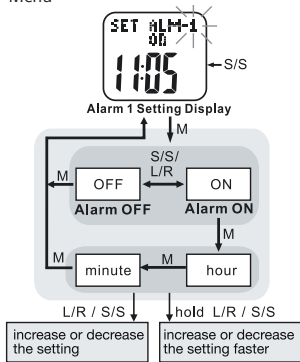

fig.13

- PRESS **ST/STP** or **LAP/RESET** to scroll to Alarm Setting: **2 of 10**
- PRESS **MODE** to enter Alarm Setting: **2 of 10**
- PRESS **ST/STP** to select from 1 of the 5 daily alarms
- PRESS **MODE** to confirm

- PRESS **ST/STP** to toggle the alarm on and off
- PRESS **MODE** to confirm

Note: if alarm is off, you will not be able to adjust the alarm time

- PRESS **ST/STP** or **LAP/RESET** to adjust the hour. Check whether the hour is for AM or PM
- PRESS **MODE** to confirm
- PRESS **ST/STP** or **LAP/RESET** to adjust the minute
- PRESS **MODE** to confirm

Repeat above steps to set the remaining alarms  
HOLD **MODE** FOR 3 SECONDS to return to the Main Settings Menu

HOLD **MODE** FOR 3 SECONDS to return to return to the Home Time display

**Exercise Schedule: 3 of 10** see fig. 10.

Your Accelerator watch has a useful scheduling feature for exercise mode. This feature allows you to determine specific times of the day when exercise mode will automatically turn on and off so that you don't accidentally forget to

record important data. Six start and/or stop times can be set in the exercise schedule. See the following steps to set your own exercise schedule.

HOLD **MODE** FOR 3 SECONDS in the Home Time display to access Main Settings Menu

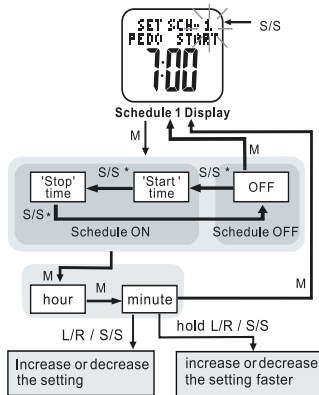

\* Press L/R to move the selection by a reverse direction.

\*\*Either a 'start' or 'stop' time can be set for a schedule

fig.10

- PRESS **ST/STP** or **LAP/RESET** to scroll to Exercise Schedule: **3 of 10**
- PRESS **MODE** to enter Exercise Schedule: **3 of 10**
- PRESS **ST/STP** to select from one of the six exercise schedule start/stop times
- PRESS **MODE** to confirm
- PRESS **ST/STP** to select between off / start / stop
- PRESS **MODE** to confirm
- PRESS **ST/STP** or **LAP/RESET** to adjust the hour. Check whether the hour is for AM or PM
- PRESS **MODE** to confirm
- PRESS **ST/STP** or **LAP/RESET** to adjust the minutes
- PRESS **MODE** to confirm

Repeat above steps to set the remaining exercise schedule start/stop times

HOLD **MODE** FOR 3 SECONDS to return to the Main Settings Menu

HOLD **MODE** FOR 3 SECONDS to return to the Home Time display

**Pedometer Setting: 4 of 10** see fig.11  
Your accelerator watch is highly customizable; just

tailor the accelerometer sensor to match your workout. See the following steps to adjust the sensitivity and sleep timer of exercise mode.

HOLD **MODE** FOR 3 SECONDS in the Home Time display to access Main Settings Menu

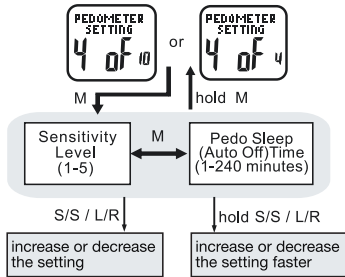

**Pedometer Setting** fig.11

- PRESS **ST/STP** or **LAP/RESET** to scroll to Pedometer Setting: **4 of 10**
  - PRESS **MODE** to enter Pedometer Setting: **4 of 10**
  - PRESS **ST/STP** to adjust the pedometer's sensitivity level from 1-5

Note: Sensitivity range is from 1=least sensitive to 5=most sensitive. In most cases, level 1 is recommended for you to achieve accurate results

- PRESS **MODE** to confirm
- PRESS **ST/STP** or **LAP/RESET** to adjust pedometer's sleep timer from 1 to 240 minutes
- PRESS **MODE** to confirm

HOLD **MODE** FOR 3 SECONDS to return to the Main Settings Menu

HOLD **MODE** FOR 3 SECONDS to return to the Home Time display

### Memory Save/Clear: 5 of 10 see fig.8

Your Accelerator watch makes it easy to quickly save or delete any current exercise data that has been recorded in exercise mode. See the following steps to save or clear current exercise data.

HOLD **MODE** FOR 3 SECONDS in Exercise Mode to access the Exercise Settings Menu

- PRESS **ST/STP** or **LAP/RESET** to scroll to Memory Save/Clear: **1 of 4**

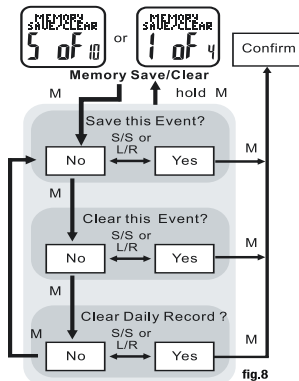

- PRESS **MODE** to enter Memory Save/Clear: **1 of 4**
- Press **MODE** to scroll through the various saving/clearing options:
  - SAVE THIS EVENT = saves data currently being recorded in exercise mode
  - Clear this event = deletes data currently being recorded in exercise mode
  - Clear daily record = deletes previously saved data for the current day, but →

maintains data currently being recorded in exercise mode

- Press **ST/STP** to select between yes/no
- Press **MODE** to confirm selection

Hold **MODE** for 3 seconds to return to the Main Settings Menu

Hold **MODE** for 3 seconds to return to the Home Time display

### Exercise History: 6 of 10 see fig.9

Your Accelerator watch contains a vast amount of internal memory. Daily exercise data is automatically stored every night at midnight. The watch's memory will store up to 7 days of individual daily exercise data and log the current day. After 7 days, the daily data is automatically cataloged into a weekly exercise record. The Accelerator's memory stores 10 weeks of records plus the last 7 days as daily exercise data. All data is stored on a rolling counter i.e.: after 10 weeks, the oldest record is replaced by the most recent weekly data. See the following steps to access the Accelerator's internal memory.

HOLD **MODE** FOR 3 SECONDS in Home time display to access the Main Settings Menu

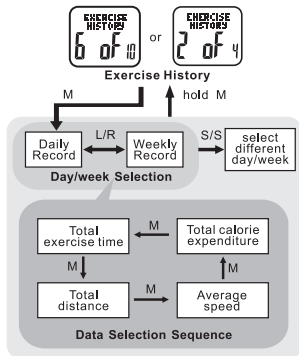

fig.9

- PRESS **ST/STP** or **LAP/RESET** to scroll to Exercise History: **6 of 10**
- PRESS **MODE** to enter Exercise History: **6 of 10**
- PRESS **LAP/RESET** to select between:
  - \* daily- previous seven days or
  - \* weekly- previous ten weeks

Example: **12-20D** = daily exercise record for December 20th

Example: **51W** = weekly exercise record for the 51st week of the year

- PRESS **ST/STP** to select the proper day or week

HOLD **MODE** FOR 3 SECONDS to return to the Main Settings Menu

HOLD **MODE** FOR 3 SECONDS to return to the Home Time display

### Timer Setting: 7 of 10 see fig.6

Your Accelerator watch has a convenient countdown timer. The timer can be used for advanced training or as a quick reminder. The timer counts backwards from your programmed time and beeps at critical intervals. See the following steps to set the countdown timer.

HOLD **MODE** FOR 3 SECONDS in the home time display to access the Main Settings Menu

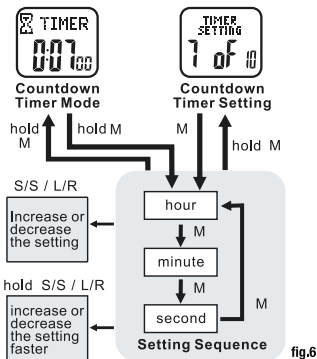

fig.6

- PRESS **ST/STP** or **LAP/RESET** to scroll to Timer Setting: **7 of 10**
- PRESS **MODE** to enter Timer Setting: **7 of 10**
- PRESS **ST/STP** or **LAP/RESET** to adjust the hour. Check whether the hour is for AM or PM
- PRESS **MODE** to confirm
- PRESS **ST/STP** or **LAP/RESET** to adjust the minutes

- PRESS **MODE** to confirm
- PRESS **ST/STP** or **LAP/RESET** to adjust the seconds
- PRESS **MODE** to confirm

HOLD **MODE** FOR 3 SECONDS to return to the Main Settings Menu

HOLD **MODE** FOR 3 SECONDS to return to the Home Time display

### Personal Profile: 8 of 10 see fig.14

Taking 5 minutes to determine your personal profile measurements is the key to enjoying your Accelerator watch. Most important is determining your average stride lengths. The greater the test distance, the more accurate your data will be. A distance of 100m or 300ft is sufficient for proper calibration. This distance is easy to measure at a local running track, as it is the length of one straightaway. Use the online stride calculator at [www.tech4o.com](http://www.tech4o.com) for help with various stride length conversions. See the following steps to set up your personal profile.

HOLD **MODE** FOR 3 SECONDS in the Home Time display to access the Main Settings Menu

- PRESS **ST/STP** or **LAP/RESET** to scroll to Personal Profile: **8 of 10**

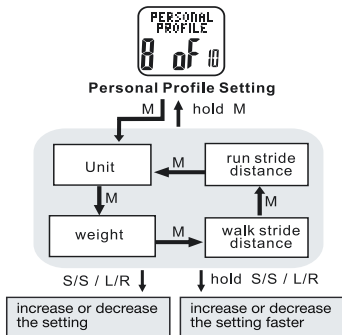

fig. 14

- PRESS **MODE** to enter Personal Profile: **8 of 10**
- PRESS **ST/STP** to select the preferred units
- PRESS **MODE** to confirm
- PRESS **ST/STP** or **LAP/RESET** to adjust the weight to match your own
- PRESS **MODE** to confirm
- PRESS **ST/STP** or **LAP/RESET** to adjust the average walking stride to →

- match your own
- PRESS **MODE** to confirm
- PRESS **ST/STP** or **LAP/RESET** to adjust the average running stride to match your own
- PRESS **MODE** to confirm

HOLD **MODE** FOR 3 SECONDS to return to the Main Settings Menu

HOLD **MODE** FOR 3 SECONDS to return to the Home Time display

### System Setting: 9 of 10 see fig.15

This section describes how to adjust various audio and visual characteristics of the Accelerator watch

HOLD **MODE** FOR 3 SECONDS in the Home Time display to access Main Settings Menu

- PRESS **ST/STP** or **LAP/RESET** to scroll to System Setting: **9 of 10**
  - PRESS **MODE** to enter System Setting: **9 of 10**
  - PRESS **ST/STP** to adjust the hourly chime on or off
  - PRESS **MODE** to confirm
  - PRESS **ST/STP** to turn the key tone on or off

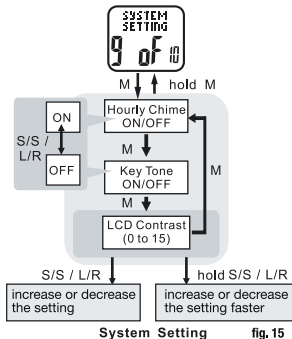

- PRESS **MODE** to confirm
- PRESS **ST/STP** or **LAP/RESET** to adjust LCD screen contrast
- PRESS **MODE** to confirm

HOLD **MODE** FOR 3 SECONDS to return to the MAIN SETTINGS MENU

HOLD **MODE** FOR 3 SECONDS to return to the Home Time display

### Dual Time Setting: 10 of 10 see fig.16

Your Accelerator watch is capable of storing →

an alternate time zone. See the following steps to set up a dual time and its various display options.  
HOLD **MODE** FOR 3 SECONDS in the Home Time display to access the Main Settings Menu

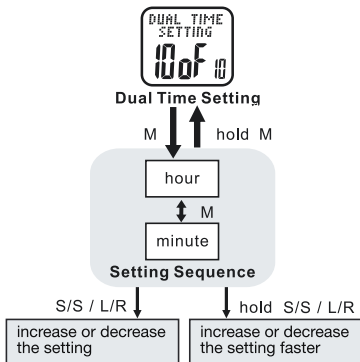

fig. 16

- PRESS **ST/STP** or **LAP/RESET** to scroll to Dual Time Setting: **10 of 10**
- PRESS **MODE** to enter Dual Time Setting: **10 of 10**
- PRESS **ST/STP** or **LAP/RESET** to adjust the

hour. Check whether the hour is for AM or PM

- PRESS **MODE** to confirm
- PRESS **ST/STP** or **LAP/RESET** to adjust the minutes
- PRESS **MODE** to confirm

HOLD **MODE** FOR 3 SECONDS to return to the Main Settings Menu

HOLD **MODE** FOR 3 SECONDS to return to the Home Time display

#### POWER SAVING MODE:

All Accelerator watches have a power saving mode to conserve battery life

HOLD **LAP/RESET** FOR 5 SECONDS from the home time display to put the watch in power saving mode.

- PRESS any button to exit power saving mode

#### BATTERY:

We recommend that you take your Accelerator watch to a proper watch service or jeweler for professional battery replacement.

However, if you have the proper tools and coin battery CR2032 it is possible to →

replace the battery yourself. For assistance call Johnson Outdoors Customer Service at 1-800-572-8822

### TROUBLESHOOTING:

#### The distance measurements are off

This situation could arise because of a few minor issues:

- **Have you properly set up your personal profile?** Although the Accelerator comes with a pre-programmed profile, a you can achieve much greater accuracy by taking 5 minutes to set your personal profile.
- **Have you properly adjusted the pedometer settings?** You may want to adjust the sensitivity or sleep timer to better match your personal stride characteristics and schedule.
- **Do you exhibit drastic variations in your running/walking pace, or is your pace different than the pace used to determine your stride length?** Accelerators work best when you maintain a relatively steady running or walking pace. This is not to be confused with the watch's ability to determine whether you

are running or walking. Your stride lengths should be measured using the same pace as you use when actually exercising.

- **I can't get rid of Dual Time!** Follow the instructions in the Main Functions Mode: Dual Time View page 5 to alter the view.
- **Exercise Mode keeps turning off.** Exercise Mode will automatically shut off to conserve battery power. You can adjust the auto shut off by adjusting the sleep timer (1-240min) by following the instructions in: Pedometer Setting: 4 of 10 in the Main Settings Menu or Pedometer Setting: 4 of 4 in the Exercise Mode Settings Menu

### LIMITED WARRANTY:

**What is covered?** Johnson Outdoors Inc. warrants your Tech<sup>4</sup>O Watch to be free from defects in materials or workmanship, and to perform accurately, for one (1) year provided it has not been damaged by the causes described in the next paragraph.

**What is not covered?** Normal wear, and damage due to the abrasion, melting, misuse, alteration, and abuse (including any disassembly) are not covered by this warranty. Digital Watches are water resistant, they are not waterproof. Damage resulting from excessive exposure to water, → heat

or cold is not covered under this warranty. Additionally, the battery is not covered under the warranty. Always have the battery replaced by an authorized repair center or jeweler. Should you do the work yourself, you may void this warranty.

#### **How to obtain warranty service or repair of your watch?**

Should a defect covered by this warranty appear in your watch, call our Consumer Service Department toll-free at 1.800.572.8822 for return authorization and instructions. (You must pay the cost of returning the unit to us). If the product is found to be defective in material or workmanship, we shall, at our option, either repair or replace it without charge, and will pay the cost of return shipment to you. If repairs are required to correct any problem not covered by this warranty, we will contact you for approval to proceed and to charge you for the components repaired or replaced, plus a nominal charge for labor.

THERE ARE NO EXPRESS WARRANTIES ON YOUR WATCH THAT ARE NOT CONTAINED IN THIS DOCUMENT. IN NO EVENT SHALL WE BE LIABLE FOR INCIDENTAL OR CONSEQUENTIAL DAMAGES ARISING FROM USING OR LOSS OF USE OF YOUR WATCH.

Some states do not allow exclusion or limitation of incidental or consequential damages, so the above exclusion may not apply to you. This warranty gives you specific legal rights, and you may have other rights which vary from state to state.



#### **U.S.A.:**

Johnson Outdoors Inc. 625 Conklin Road,  
PO Box 966 Binghamton, New York 13902  
johnsonoutdoors.com  
camping@johnsonoutdoors.com  
Phone: 607.779.2222 Toll Free: 1.800.572.8822  
Fax: 607.779.2293

#### **Canada:**

Johnson Outdoors Canada Inc.  
Ontario, Canada L7L 6B6  
Phone: 905.634.0023 Toll Free: 1.800.263.6390  
Fax: 1.800.661.1170

#### **Europe:**

Geor Nicolaas,  
Nigor net BV [www.eurekaeurope.com](http://www.eurekaeurope.com)  
P.O. Box 92257 Kabelweg 100  
1090 AG Amsterdam 1014 BC Amsterdam  
E [info@nigor.net](mailto:info@nigor.net)  
T+31-20-5818 555 T+31-20-5818 559

#### **For technical help: [www.tech4o.com](http://www.tech4o.com)**

Johnson Outdoors Inc. © 2007 Rev. A 10.07

**TECH<sup>4</sup>O<sup>®</sup>**  
NOTHING'S BEYOND YOU.